

# Chapter 20

## Parallel Printer Port

There are several ways to connect a printer to the SK68K - a serial printer can be connected to the serial port at J21, a parallel printer can be connected to the printer port on a monochrome video card, or a parallel printer can be connected to J8 on the SK68K system board. All of these are supported by SK\*DOS drivers, and it is even possible to connect all three printers at once. This step discusses the parallel printer port at J8.

### 20-1. Discussion

As Fig. 20-1 shows, there isn't actually much to discuss - the entire port consists of just U2, an MC68230 parallel interface/timer IC (PI/T) which is part of the Motorola 68000 family. The 68230 consists of essentially three

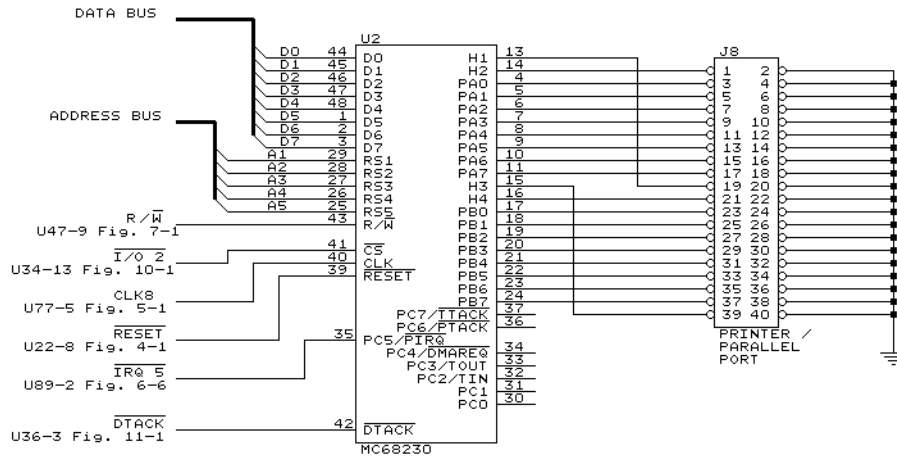

Fig. 20-1. Printer / parallel port.

parts:

*Port A* is an eight-bit input/output port which uses the eight PA pins along with two *hand-shaking* pins called H1 and H2. The PA pins are data pins for the eight-bit parallel data, and can be used for both input and output; H1 and H2 are used for hand-shaking; that is, for sending control information. When used with a printer, port A (via pins 1-20 on J8 - pins 21-40 are not used in this case) connects to a Centronics-compatible parallel printer connector. The PA lines carry characters to the printer, H2 tells the printer that a character is ready, and H1 lets the printer tell the SK68K whether it is ready or busy.

*Port B* is a second eight-bit port similar to port A but using PB, H3, and H4 lines instead of PA, H1, and H2. Although it could also be used to drive a printer, in most cases it will not be connected (when using port A to drive a parallel printer, don't connect to J8 pins 21-40.)

The third part of the 68230 PI/T is a timer. This is a 24-bit counter which can count either CLK8 clock pulses or external pulses, generate square waves, generate interrupt signals to the computer at fixed time intervals, and various other functions. It is not used by SK68K software, but there is no reason why you can not use it in your own programs.

On the CPU side, the 68230 connections are similar to those of the floppy disk controller. It receives the  $\overline{I/O2}$  signal from the address decoder, so it is selected whenever any address in the range of \$FE0080 through \$FE00BF appears on the address bus. Like the FDC, it contains a number of internal registers which are accessed at specific addresses, depending on the status of address lines A1 through A5. But there are just too many registers and operating modes to describe here - Motorola publishes a 75-page manual on this IC alone!

## 20-2. Construction

Install the following components:

U2	MC68230 PI/T and its socket
J8	40-pin header
C2	0.1 $\mu$ F disk capacitor

Fig. 20-2 shows how to construct the printer cable with 20-conductor flat cable. You may use a 20-pin connector at the computer end if you make sure to install it only in the pin 1 end of J8; otherwise, use a 40-pin connector and make sure to attach the 20-wire cable all the way toward the pin 1 end. Place a standard Centronics printer connector at the other end, making sure that pin 1 of this connector connects to pin 1 of the other connector.

## 20-3. Testing

Connect a standard Centronics-compatible parallel printer to J8, and then boot SK\*DOS (with the FD command).

To use the printer, you must first install the parallel printer driver. From the SK\*DOS prompt, use the command

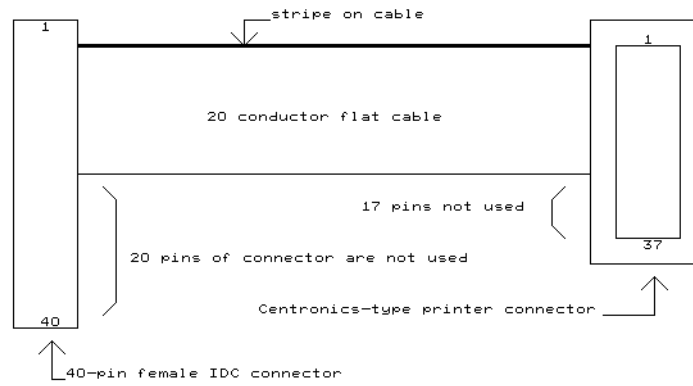

Fig. 20-2. Parallel printer cable.

**DEVICE PARALLEL AS PRTR AT 2**

This installs the PARALLEL.DVR driver from the disk as device 2 and gives it the name PRTR. To try out the printer, try any SK\*DOS command, but insert the text >PRTR on the command line to redirect the output from the screen to the printer. For example, the command

**ACAT >PRTR**

would print an alphabetized catalog of the disk on the printer.

