Chapter 21

Optional -HDO Hard Disk Port

Rejoice - this is the last section of your SK68K computer to be wired. In fact, most users will probably choose to omit this section.

21-1. Discussion

The cheapest way to add a hard disk to your SK68K is by using a Western Digital WDXT-GEN (or -WX2) type hard disk controller, plugged into one of the XT-style connectors on the back. These controllers cost about \$70, or can be obtained complete with a 20-megabyte disk and cables for under \$250.

Still, there are some users who wish to use a more expensive controller, the Western Digital WD1002-HDO which alone costs about \$250, because they want to keep all their XT-type slots open for other purposes. The -HDO hard disk port shown in Fig. 21-1 is for them; all others can simply skip this part since the -HDO controller has no other advantages. (While both hard disk controllers can be installed at the same time, they require slightly different versions of SK*DOS and therefore cannot be used at the same time.)

The -HDO controller connects to the SK68K with a 40-pin flat cable connected to J17. It needs the data bus, three bits from the address bus to select internal registers (buffered address lines BA0 through BA2, obtained from the XT-type interface connectors are used), the $\overline{I/O5}$ signal which selects this port at addresses \$FE0140 through \$FE017F, RESET, and a pair of signals called \overline{WE} and \overline{RE} for write enable and read enable, which are generated by U15b and U15c from the R/ \overline{W} signal and a port-select signal derived from U16.

U16 is essentially a digital delay used to generate \overline{DTACK} . Each time the -HDO port is selected by $\overline{I/O5}$ and the AS address strobe signal arrives, U16 starts to shift the AS signal from stage to stage. After two CLK8 clock

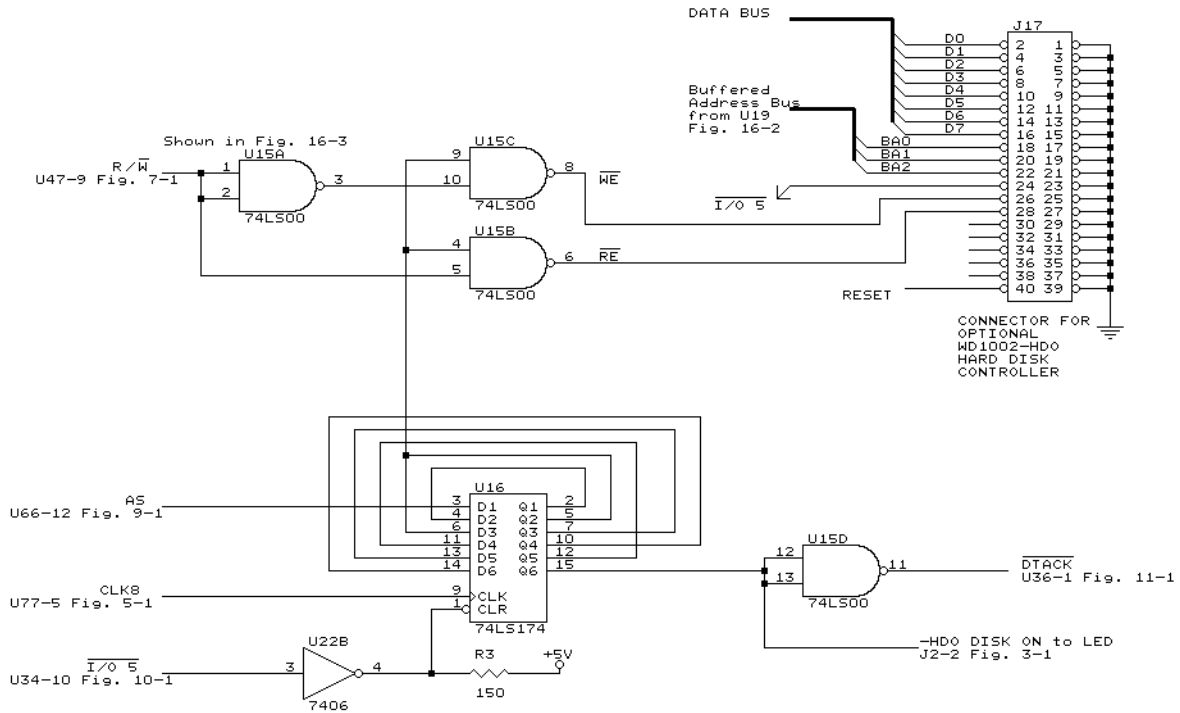

Fig. 21-1. -HDO hard disk controller port.

pulses, it sends a signal up to U15b and U16c to generate either \overline{WE} or \overline{RE} , depending on whether the system is reading or writing. After six clock pulses, it sends a pulse to U15d, which then generates \overline{DTACK} .

21-2 Construction

First, **remove the jumper between U15 pin 7 and pin 12**. When we installed U15 in Chapter 16 as part of the XT-type bus connector circuitry, we put in this jumper to prevent U15d from generating a constant \overline{DTACK} which would prevent the rest of the computer from working properly. Then install the following parts:

- U16 74LS174 hex type D flip-flop and its socket
- R13 150-ohm 1/4-watt resistor
- J17 40-pin header

Other components, such as R10, U15 and U22 have been installed in previous steps, so this completes the installation.

21-3. Testing

There is no easy way of testing this port if you do not have an actual -HDO controller.

If you do, then plug in the controller with a 40-pin cable and start the computer. First, boot SK*DOS from a floppy disk using the FD command. If your hard disk is empty, you will have to format it with the HDFORMAT command; if it already has files on it, then use the DRIVE command to assign it a drive number and check its contents with the DIR command.

