Chapter 3

LED Indicators

First, a bit of theory and some terms we are going to need later. Even if you know all about logic circuits, read on - some of these concepts are a bit different in real life from the way they are sometimes written up in simple books and magazine articles.

3-1. Discussion

Digital circuits represent the binary digits 0 and 1 by means of voltages; in most microcomputers, the two voltages are often called low (which is a voltage between 0 volts and roughly 0.8 volt) and high (which is a voltage between about 2 volts and 5 volts). There are a few exceptions, of course - such as in an RS-232 circuit between a computer and terminal where larger positive and negative voltages may appear - but lows near 0 volts and highs near 3 to 5 volts are the most common. In any case, the range between 0.8 volts and 2 volts is a no man's land; if a digital signal is in that range it usually indicates a problem somewhere.

Many people think that a low voltage is a 0, while a high voltage is a 1, but this is not always true - it could be the other way around. So talking about ones and zeroes can be ambiguous, while talking about lows and highs is always quite specific. Note that we don't really care about the exact value of a signal's voltage, so long as it falls into one of these two ranges.

But we can talk about digital signals in a different way as well - we can say that a particular signal is on, or off. Computer people, however, like somewhat longer words - they say that a signal is asserted when they really mean it is on, and they may say that it is negated when it is off.

Now comes the problem - some circuits use a high to mark a signal as on (asserted), while other circuits may use a low to turn on (assert) a signal. So we run into two types of circuits:

A so-called active high circuit is one which is high when asserted (on), and low when negated (off); some books call this positive logic. A so-called active low circuit is one which is low when asserted (on), and high when negated (off); some books call this negative logic. In a typical computer, both kinds of circuits may be used, and often an active high circuit may be just a tenth of an inch from an active low circuit.

Many of the signals in this text and diagrams are assigned meaningful names. Whenever you see a name which has a “not bar” either above or below its name, such as $\overline{\text{HALT}}$ you will know that this signal is active low. On the other hand, a signal without the not bar, such as FC0 or A16, is active high. Because it is difficult to place not bars over signal names in text, many people use alternative ways of marking active low signals; some common ways are with an asterisk, as in HALT*, a minus sign, as in -HALT or HALT-, or with a lower case letter n, as in nHALT. We will use the not bar above the name in this book.

LED Indicators

If, instead of using an XT-clone cabinet, you use what is commonly called a “mini-AT” cabinet (because it is the size of an XT cabinet, but is built in the style of an AT cabinet), you will note that such cabinets have two or three status indicator LEDs on the front panel. These LEDs can eventually connect to J15, J16, and J17 on the SK68K board as shown in Fig. 3-1 (which also shows the speaker wiring.) In each case, a resistor in series with the LED (or speaker) limits the current through it, while the LED (or speaker) is controlled by a section of U32, a 7406 open collector gate. (Note that U32c, U32f, U32d, and U32b are all part of the same U32 IC; U32 has six such inverters, and the other two are used elsewhere. The numbers on the

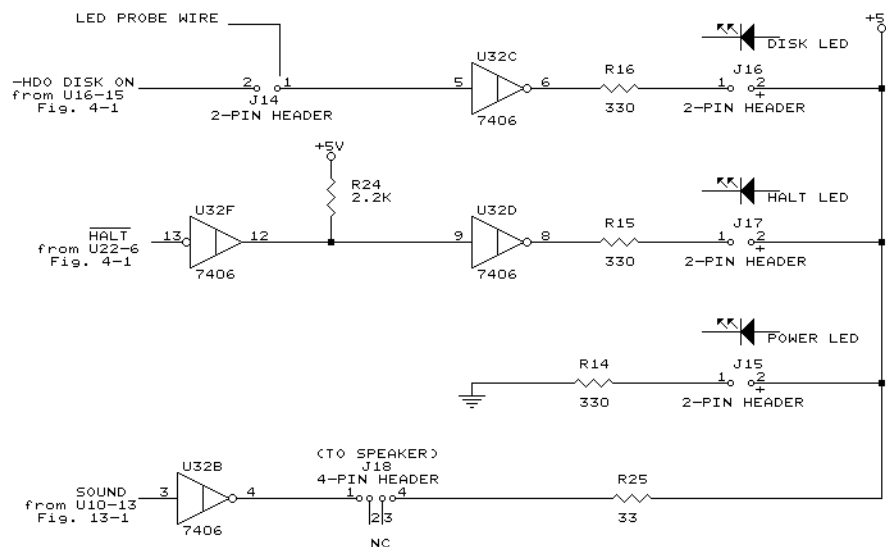

Fig. 3-1. LED and speaker circuit.

outside of the triangle, next to the leads, are the pin numbers. The vertical line inside the U32 symbol marks this as an open collector device, explained shortly. Ignore the fact that U32f has a small circle, called a bubble, on its input side instead of the output; this is just a different notation and will be explained next time shortly.

The LED at J15 lights whenever there is +5-volt power, while the LED at J17 lights when the 68000 is halted, and the LED at J16 lights to indicate hard disk use.

3-2. Construction

Since many users of the SK68K do not have access to an oscilloscope or even a logic probe, the wiring for the LED at J16 has been set up to allow its use as a simple logic probe. Furthermore, during construction you will not have the printed circuit board mounted in the cabinet, and so we want to connect LEDs directly to the board for immediate use. (This is especially important for the HALT LED, which will be very useful during checkout of the board.)

We therefore wire the circuit a bit differently. Refer to Fig. 3-2, the parts layout, and install the following parts:

R14, R15, and R16	330 ohm 1/4-watt resistors
R24	2200 ohm 1/4-watt resistor
C11	0.1 μ F disk ceramic capacitor
	14-pin socket for U32
R25	33 ohm 1/4-watt resistor
J18	4-pin header strip

Do not install U32 in its socket yet. (R25 and J18 are not needed yet, but this is a convenient time to install them as the speaker wiring is so similar to the LED wiring. But do not connect the speaker yet.)

Then install the three LEDs at J15, J16, and J17. The negative lead of each LED, usually marked by a small flat on the side, should go toward the resistors. If at all possible, check each LED first, since many times LEDs available on the open market are wired opposite to this convention.

Install each LED so it stands up straight, but the bottom of the LED is about 1/2" above the board. (The reason: When we're ready to mount the board in the cabinet, we will cut off each LED lead just below the LED itself, and use the stubs of the LED leads as connectors for the panel-mounted LEDs.)

3-3. Testing

Now connect the power supply to J10 and power up the board. The POWER LED should light, though it may immediately go off again. If so, don't be alarmed - most PC-type power supplies shut themselves off if there is not enough of a load on them, and a single LED is a very small load indeed. Simply turn off the supply, temporarily connect the 150- or 330-ohm

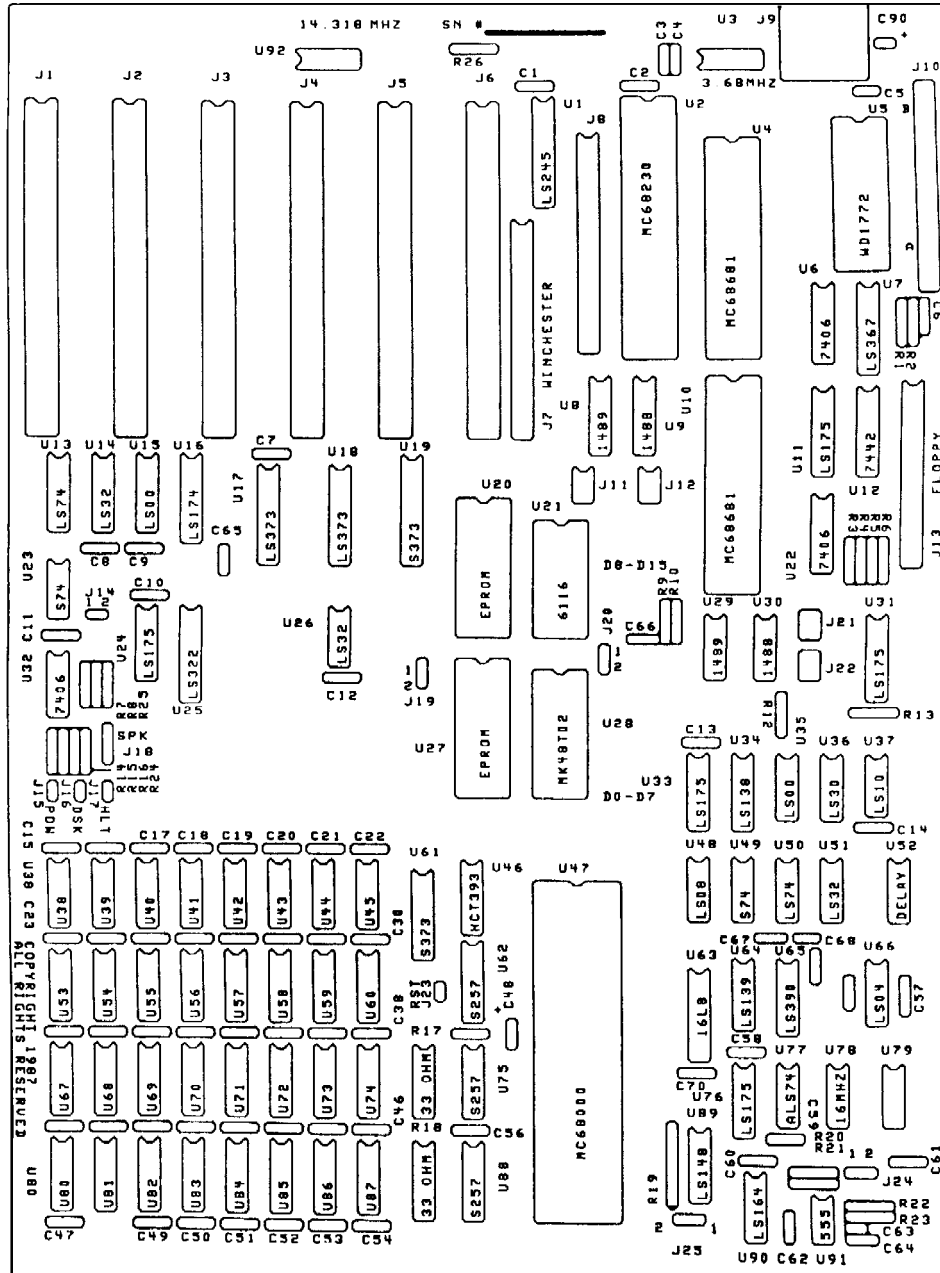

Fig 3-2. Printed circuit board layout.

resistor between pins 7 and 14 of the U32 socket (don't force the leads into the socket) and try again. This should add just enough of a load to allow the supply to turn on.

If the LED does not light at all, even for an instant, then most likely either the LED is in backward, R14 is the wrong value, or the power supply is

defective or not properly connected to J10A and J10B. Correct the problem before continuing.

NOTE:

During construction, we will often wire something, turn on the power and try it out, turn off the power, wire some more, and so on. It is absolutely essential that you turn off the power before doing any wiring, soldering, or inserting ICs into sockets. Better yet, turn off the supply and also unplug it. If you slip and forget to turn off the power, you may well burn out part or all of the components on the board, and perhaps even burn out a few of the traces as well.

So now turn off the power, connect a thin wire about 12-15" long to terminal 1 of J14. Try to use a thin solid wire, about 30 gauge. If you use a stranded wire, then twist the strands of the loose end and cover them with a bit of solder so they stick together. Next, insert a 7406 IC into U32 (remove the 150- or 330-ohm temporary resistor). Note that all ICs on the entire board are oriented the same way - pin 1 (marked by a dimple or notch, both on the IC and also on the silk screen layer on the board) goes toward the back of the board. Then turn the power back on.

The wire connected to J14-1 (which is shorthand for terminal 1 of J14) is now a test probe, which we will call the LED probe. If you ground its loose end (to pin 7 of IC32, for example) then the LED at J16 should go off; if you connect it to a high voltage (pin 14 of IC32, for instance) then the LED should go on. The J16 LED now makes a simple logic probe which can be used to check out other parts of the computer. (If you have a meter, oscilloscope, or real logic probe, then feel free to use it instead, but you may still occasionally want to use this built-in probe instead.)

When the LED probe wire is connected to a low or ground, the LED will be dark; when connected to a high or +5 volts, it will be brightly lit. When it is not connected to anything at all, then the LED will be on, for the simple reason that TTL ICs see a disconnected input as if it were high. When connected to a source of pulses, the LED will light, but its brightness will depend on the type of pulses - a pulse signal which is high most of the time will be brighter than one which is mostly low. If you connect the LED probe to a pulse signal, the LED will usually dim slightly from its normal bright light (because of the open circuit); this is an easy way to recognize a pulse signal.

